

A.7: Beam profile measurement system for industrial electron linac

Electron linacs capable of delivering maximum beam energy of 10 MeV are being developed by RRCAT for applications in Agricultural Radiation Processing Facility (ARPF). For characterization of electron beam of industrial linac, the control and processing electronics for beam profile measurement system has been developed and deployed by Beam Diagnostics Section (BDS) of Indus Operations, Alignment & Beam Diagnostics Division (IOABDD).

The beam profile measurement system consists of a Beam Profile Monitor (BPM) having two movable slit blades, one in horizontal and one in vertical direction, which scan the beam transversely. The slit blade is moved across the beam and current signal proportional to the portion of the beam falling on it versus blade position is measured by a control and processing electronics to determine the beam profile, beam size and beam position. The block diagram for the developed control and processing electronics of BPM is shown in Fig. A.7.1.

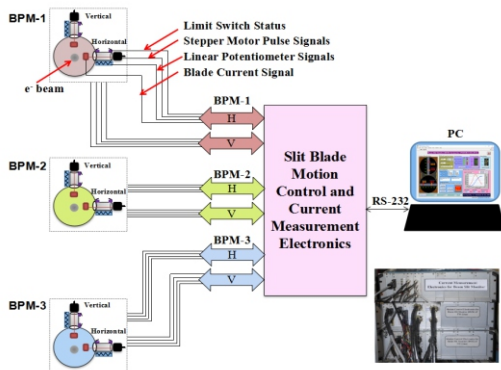

Fig. A.7.1: Block diagram of beam profile measurement electronics (Inset: Photograph of BPM electronics)

The control electronics precisely controls the motion of slit blades using stepper motors. It acquires the position read back of slit blades using linear potentiometer. It also monitors limit switch status to prevent the motion of blades beyond set limits. The accuracy of positioning of slit blades is better than 100 μm. A switched integrator based electronics has been developed which measures integrated current signal, proportional to the portion of beam falling on the slit. Its input current measurement range is from 0.3-300 mA and its accuracy is better than ±1%.

A LabVIEW based GUI software has been developed to control the slit blade motion and to acquire integrated blade current signal data of BPM. It calculates transverse beam profile based on 5-point Savitzky-Golay derivative algorithm and displays the measured beam profile parameters such as

beam center, beam size, blade current etc. in a short time. It stores the acquired data in a file on a PC. A screenshot of the developed GUI of the beam profile measurement system is shown in Fig. A.7.2.

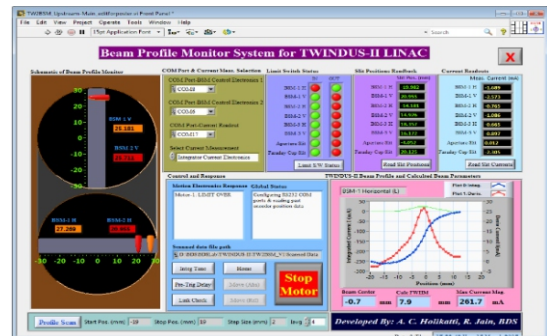

Fig. A.7.2: Screenshot of graphical user interface of beam profile measurement system

Fig. A.7.3 shows typical results of horizontal and vertical beam profile measurements taken with the linac operating at beam current of ~260 mA and a pulse repetition rate of 1 Hz. The snapshot of BPMs installed in the linac is shown in Fig. A.7.4.

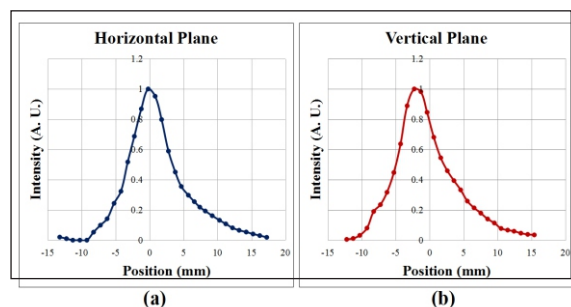

Fig. A.7.3: Typical result of beam profile measurement system (a) Horizontal plane (b) Vertical plane

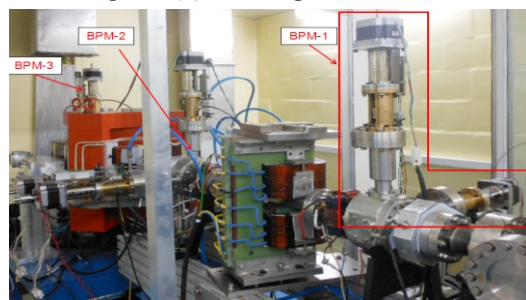

Fig. A.7.4: Snapshot of installed BPMs

The beam profile measurement system is being routinely used to characterize the beam during various experiments being conducted to improve the performance of the linac.

Reported by:
A. C. Holikatti (anilch@rrcat.gov.in), Rahul Jain