

### A.2: Reference generator for pulse selector magnet power supply of 10 MeV linac

A linac based Agricultural Radiation Processing Facility (ARPF) is being setup by RRCAT for irradiation of agricultural products, for which 10 MeV electron RF linacs are being developed indigenously at RRCAT. Testing of one of the linacs with specifications 10 MeV, 6 kW (average) is under progress at RRCAT. This linac has an electron beam current of approximately 450 mA. Pulse width of the electron beam is 10  $\mu$ s and the Pulse Repetition Rate (PRR) is 220 Hz. A beam diagnostic line is connected to the linac along with the normal beam delivery line. A pulse selector magnet (PSM) is used to divert the electron beam normally in the beam delivery line and selected beam pulses in the beam diagnostic line. A typical reference generator is developed by ACS D for excitation of power supply for PSM, which provides programmability of operation of the power supply.

Maximum energy of the electrons in the beam is to be limited to 10 MeV for irradiation of material with electrons and 7.5 MeV for x-ray irradiation. These limits are imposed by the regulatory authorities. Spatial parameters of the beam are also important beam characteristics. Characterization of delivered electron beam for mean beam energy and the energy spread is thus necessary along with the measurement of spatial parameters. beam diagnostic line (BDL) is developed by IAD, RRCAT for characterization of electron beam even during the high power operation of linac. The BDL, having beam diagnostic devices mounted on it, is inline extension of the linac structure and referred as 0° line. There is a beam delivery line also connected at the end of the linac structure at 30°. Normally, PSM bends electron beam from linac to the 30° line and sends a programmed selected number of beam pulses per second to BDL. For this, analog reference waveform is given to the power supply for PSM, which drives the PSM with the analogous current. A standalone electronic module is developed to generate the reference of the required specification. As shown in Figure A.2.1, it has a digital logic and an analog switching circuit. Analog switching block has an input which can be fed from either an external reference source in standalone mode or from an onboard DAC that can be programmed through a VME bus based interface. Output of the analog block is the DC reference required for PSM power supply to bend beam at 30°. The digital logic has a counter that counts the incoming trigger pulses. Outputs of the counter are fed to one side inputs of a digital comparator, other side inputs of which are programmed with DIP switches or an onboard latch (set by the VME interface). The comparator produces an “equal” signal when the counter output is equal to the programmed counts. Output of the analog block is brought down to zero upon receiving the “equal” signal and thus the reference to the P/S of PSM (Figure A.2.2). At this event the beam pulse goes straight to the beam diagnostic

devices. The “equal” signal is also output for triggering other measurement equipment.

Thus the module has standalone manual as well as remote programmable modes. It is also designed for use as an I/O board for VME based control system to be used in remote mode. It has a 16 bit DAC which can be programmed by the CPU on VME bus. Diagnostic pulse count can also be programmed by the CPU. External reference source is not required in remote programmable mode.

PSM reference generator is tested with the real system and few experiments are carried on linac using this reference generator while the linac was operated at high power.

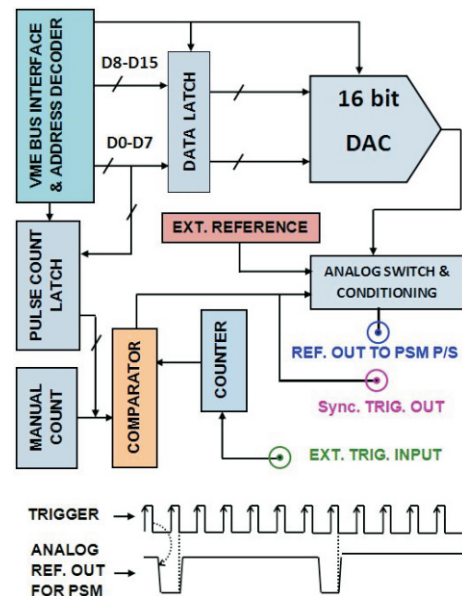

Fig. A.2.1: Scheme of the PSM reference generator.

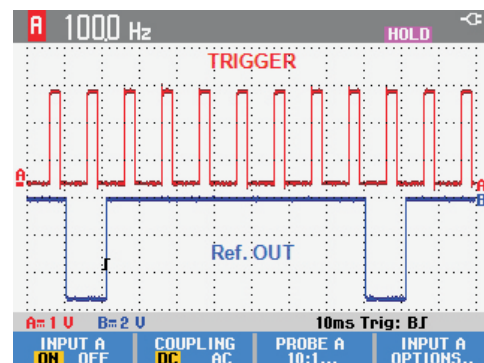

Fig. A.2.2: Trigger and reference output waveforms.

Reported by:  
Dipak Sahu (dipaksahu@rrcat.gov.in) and Yogendra Sheth